



PROVISIONAL DATASHEET

P 120.10 HM

Extraordinary performances



Building with confidence.

P 120.10 HM steel muscles.

The new Panoramic P 120.10 HM telescopic handler enhances the Merlo designing concepts because it ensures high-level performances maintaining reduced dimensions.

Even if the Panoramic P 120.10 HM is the more compact in its category, it can lift up to 12 tons and reach operational heights of up to 10 meters.

This machine has been specifically designed to enhance operational performance levels and to ensure highly effective solutions in all heavy-duty handling operations typical of sectors as those of cereals, of wood and of refusals.

The exclusive fittings further boost its intrinsic potential, of which the most important is the Merlin (Merlo Local Interactive Network) computerized system.

Thanks to this unique technology all operating parameters are analyzed by the main computer which elaborates them and ensure the highest safety in every moment in order to allow the operator to concentrate only on the job.

The hydraulic system has a single variable displacement piston pump with Load-Sensing control: this solution permits the regulation of the hydraulic oil flow to immediately adapt to the demands of the hydraulic services auctioned, even at low engine rpm.



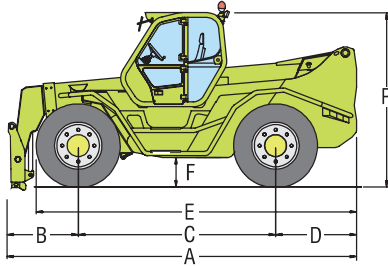

Dimensions	P 120.10 HM
A (mm)	5740
B (mm)	1165
C (mm)	3240
D (mm)	1335
E (mm)	5235
F (mm)	450
H (mm) ⁽¹⁾	2400
M (mm) ⁽²⁾	995
P (mm)	2850

⁽¹⁾Machine width.

⁽²⁾Internal width of the cabin.

PANORAMIC P 120.10HM

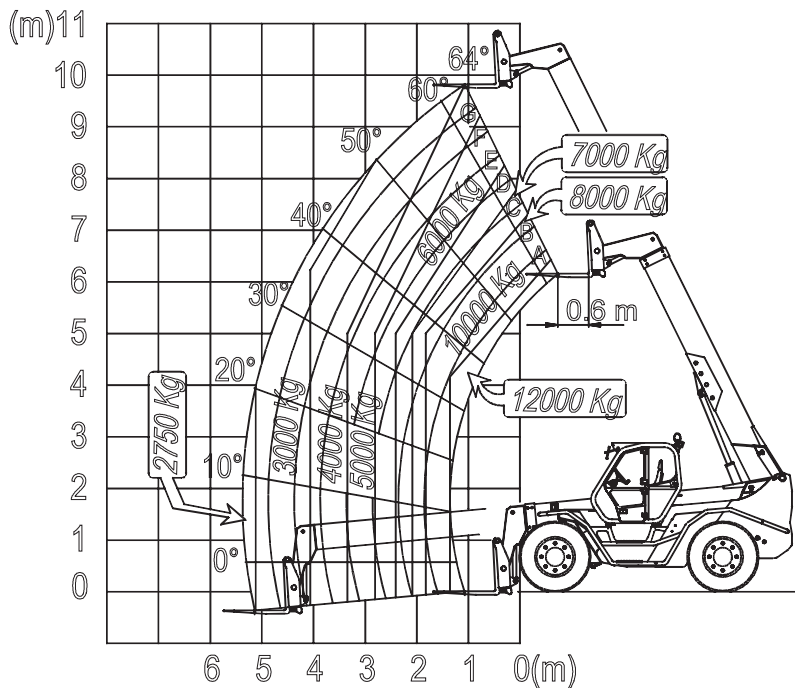

Characteristics and performances P 120.10 HM

Total empty weight with forks (kg)	15650
Maximum rated capacity (kg)	12000
Maximum lift height (m)	9,8
Maximum forward reach (m)	5,7
Maximum height at maximum load (m)	6,4
Forward reach at maximum load (m)	1,4
Lift capacity at full lift height (kg)	5000
Lift capacity at maximum forward reach (kg)	2750

Engine

Low emission engine (Euro 3)	6 cylinder turbo
Power at 2300 rpm (kW/CV)	107/145

Maximum speed

1 st range	16
2 nd range (self-lifting speed)	40

Accessories

Hydraulic distributor on the boom	●
Radio-control for lifting operations	○
Cab mounted working lights	○
Front screen protection	○
Prearrangement for 2 hydraulic services	○
Antitheft system with immobilising device	○
Air conditioning	○

● Standard ○ Option

Cab

In compliance with ISO 3449 (FOPS) and ISO 3471 (ROPS) directives.

Boom

Telescopic with sections sliding on adjustable anti-friction pads. Integrated hydraulically operated device for side shift.

Tool-carrier carriage

Hydraulic quick coupling/detachment device directly controlled from the cab.

Steering

Four wheel steer, with three steering modes selected from the cab.

Engine

6 cylinder turbo intercooler diesel engine, with water cooling and rated at 107 kW (145 HP) at 2300 rpm (97/68/CE).

Transmission

Hydrostatic with electronically regulated variable displacement motor. Finger-Touch system which permits change in driving direction even when the machine is moving, without the operator having to remove his hands from the steering wheel. Permanent four wheel drive traction.

Brakes

Hydraulically controlled oil immersed disc service brakes. Automatic hydraulic park brake with hydraulic release feature.

Hydraulic system

Load-Sensing type. Variable displacement axial hydraulic pump. Maximum flow: 144 l/min. Service pressure: 230 bar.

Capacities

Hydraulic system: 180 l
Fuel tank: 185 l
Hydrostatic oil: 12 l
Engine oil: 12 l
Engine cooling: 12 l

Merlo Group power of ideas.



Powder painting.

'Merlo' is synonymous with advanced technology in the world of telescopic handlers and operated plant, and its history is one of ideas and innovation.

Not without reason do Merlo machines represent the perfect integration between the most diverse handling problems and the most innovative and productive technical solutions.

It means focussing on a single project and all the contemporaneous ones, on ideas and results, on designing to win, proposing innovative solutions, anticipating applications and possible changes in a very competitive market.

This winning attitude is to be seen in the drive for an integrated production process, in modern construction methods, automatic processes, integrated electronics, robotics and in many, many other ways.

The will to always maintain a closer bond with our users is reflected in programmes for training and updating personnel, in after sales service, and in the confidence of our dealers and salesmen.

And the results are compact and productive machines assuring unequalled levels of comfort, efficiency and safety.

That is the strength of the Merlo Group.



Building with confidence.



MERLO S.p.A. Via Nazionale, 9 - 12010 - S. Defendente di Cervasca - Cuneo - Italy
Tel. +39 0171 614111 - Fax +39 0171 684101 - www.merlo.com - info@merlo.com

COMPANY
WITH QUALITY MANAGEMENT
SYSTEM CERTIFIED BY DNV
=ISO 9001:2008=